

		REVISIONS			
ZONE	REV.	DESCRIPTION		DATE	APPROVED

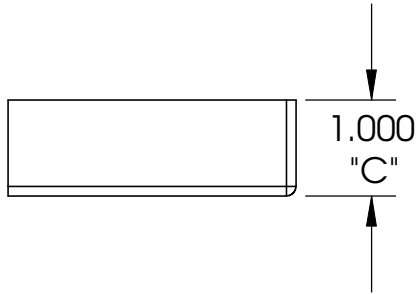

"PartNo"	"A"	"B"	"C"	"MATERIAL"	"WEIGHT"	"SLOTS"
Example001	3	4	1.000	Aluminum Bronze	0.26	4
Example002	4	5	1.333	Aluminum Bronze	7.123	
Example003	5	6	1.667	Aluminum Bronze	7.495	6
Example004	6	7	2.000	Aluminum Bronze	22.457	
Example005	7	8	2.333	Aluminum Bronze	18.972	8

Example001 Example002 Example003 Example004 Example005

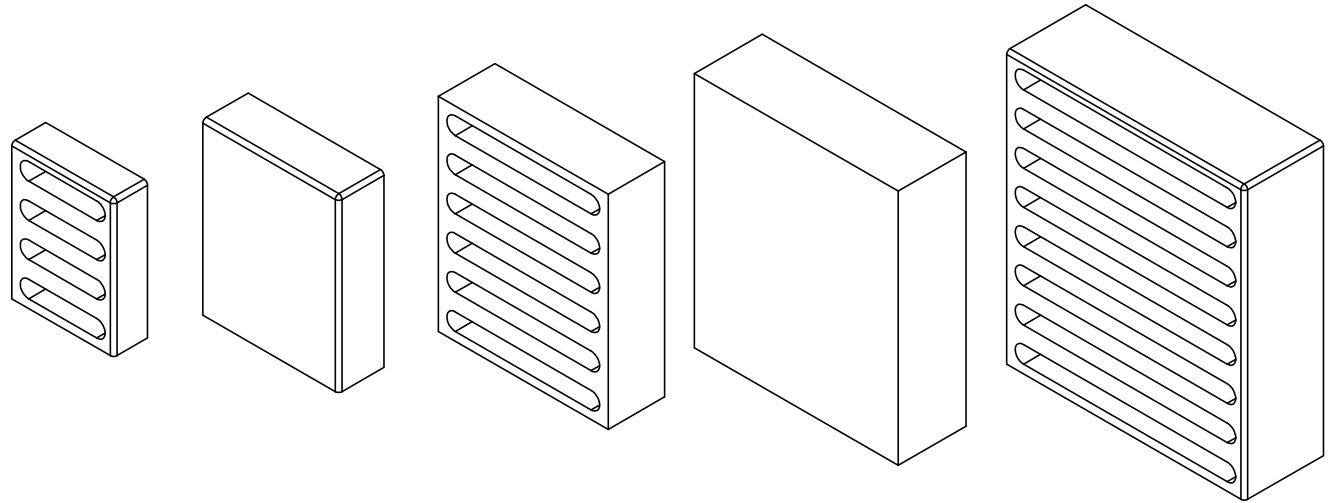
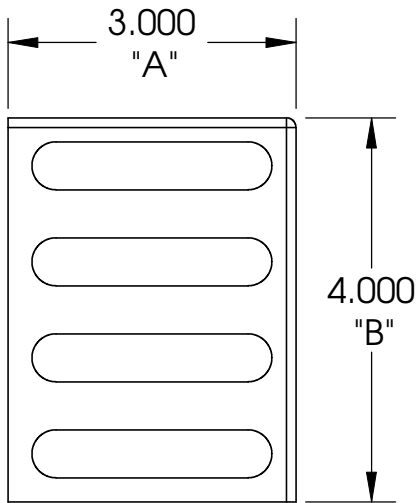

PROPRIETARY AND CONFIDENTIAL
 THE INFORMATION CONTAINED IN THIS DRAWING IS THE SOLE PROPERTY OF ENGINEERING TRANSPORT, LLC. ANY REPRODUCTION IN PART OR AS A WHOLE WITHOUT THE WRITTEN PERMISSION OF ENGINEERING TRANSPORT, LLC IS PROHIBITED.

		INCH TOLERANCES: FRACTIONAL $\pm 1/8$ ANGULAR: MACH $\pm 0.1^\circ$ BEND $\pm 1^\circ$ TWO PLACE DECIMAL ± 0.015 THREE PLACE DECIMAL ± 0.005	NAME	DATE	ENGINEERING TRANSPORT, LLC MISHAWAKA, IN
			DRAWN		
		MATERIAL	CHECKED		
			ENG APPR.		
		FINISH	MFG APPR.		
			Q.A.		
NEXT ASSY	USED ON	DO NOT SCALE DRAWING	COMMENTS:		SIZE A
APPLICATION			SCALE:1:2	WEIGHT:0	
				SHEET 1 OF 1	